



## Model

**CENTRO 250 W1 - CENTRIFUGAL FAN**

## Description

250mm inline centrifugal duct fan, 1.2m power cord

## Application

Kitchens / Commercial / Apartments / Carparks / Industrial

## Technical specification

Voltage [V/50 Hz]	220-240 AC
Power [W]	230
Current [A]	0.76
Extract capacity [m <sup>3</sup> /h]	1080
Noise level 3m [dBA]	50
r.p.m.	2090
Installation type	Inline duct
Installation position	Any
DN (diameter nominal) [mm]	250
Air flow temperature [°C]	-25 - +50
Index of protection	IP X4
Internal thermal protection	Manual reset
Colour	Blauberg grey
Casing material	ABS plastic
Warranty	5 years

## Characteristic curve

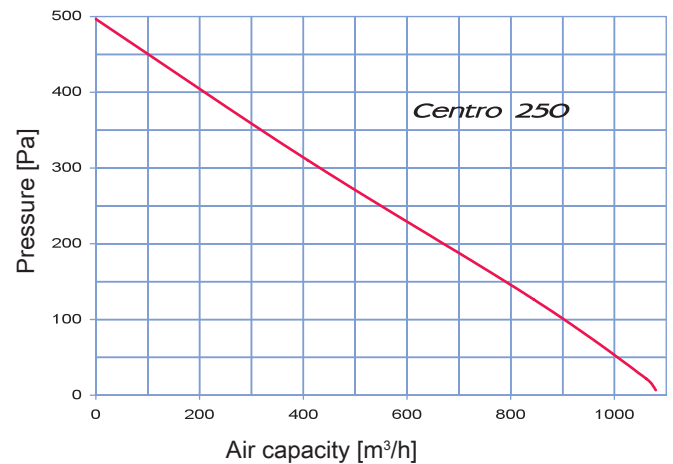

## Dimensions [mm]

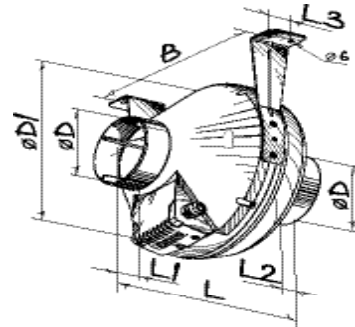

Type	Dimensions [mm]				
	d	d1	l	b	l1, 2, 3
Centro 250 W1	250	340	265	354	30

## Sound power levels

Sound pressure level	Octave-frequency band [Hz]								
	Gen	63	125	250	500	1000	2000	4000	8000
LwA to inlet, dBA	75	59	64	69	68	66	62	53	46
LwA to outlet, dBA	73	62	68	71	72	70	62	55	50
LwA to environment, dBA	67	58	62	61	50	41	37	44	38

Ventilation Solutions Australia (VSA) is not responsible for mistakes or printing errors and retain the right to make technical modifications without giving prior notice.

Email: [info@ventilationsolutions.com.au](mailto:info@ventilationsolutions.com.au)  
 Phone: 1300 998 326

